

 **ARAD**
Water Measuring Technologies



sonata
Ultrasonic Residential Water Meter

| Tuning into the future



FARMER BOY[®]

50 West Stoever Ave. • Myerstown, PA 17067
1-800-845-3374 • www.farmerboyag.com

Winner of IF Design Award 2016

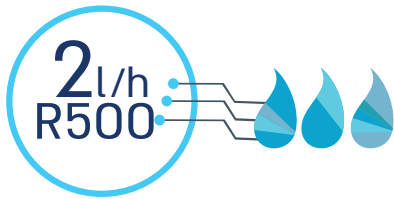

 **ARADGROUP**
Integrated Metering Technologies



Introduction

The Sonata is an advanced and highly accurate ultrasonic water meter and data end-point for residential applications. With no moving parts, the Sonata's robust design ensures reliable and long lasting precision. Its technology enables the measurement of even the lowest flow rates, making it the best solution for addressing NRW. The Sonata is fully IoT compatible - ready to meet the challenges of tomorrow's smart water networks.

Groundbreaking Performance

The Sonata has a measurement range of R500. It measures the lowest flow rates (down to 2 l/h) yet will also provide outstanding performance above the maximum flow rate. The Sonata's ultrasonic technology leverages ARAD's years of experience with its ultrasonic OCTAVE bulk water meter.

- Installation in any position
- No air measuring
- Indifferent to sand and particles in the flow
- Bi-directional flow measurement

Exceptional Reliability and Life Span

The Sonata has no moving parts, presents an IP68 register, and its body is fabricated from durable PPS composite. This robust design makes the Sonata maintenance-free and highly precise throughout its exceptional 12-year battery operated life span.



According to the communication configuration

Clear See-Through Design

The unique patent pending see-through flow tube design creates an obstacle-free water passage, minimizing pressure loss over the meter and positioning the Sonata as the lowest head loss meter available.



The Solution for Addressing NRW

With R500 rating and starting flow of 2 l/h, the Sonata is a powerful solution for addressing NRW - detecting leaks, physical water losses as well as improving consumer's awareness and satisfaction.

Data End Point

The Sonata data collection and logging capability can provide a high resolution detailed local consumption profile and help utilities inform customers on unusual consumption patterns or events. This promotes customer engagement and resource awareness.

Multiple settable alarms and events include Leak, Backflow, Pipe Bursts and dry pipe.

The non-volatile flash memory ensures no data loss even in cases of end-of-battery life.

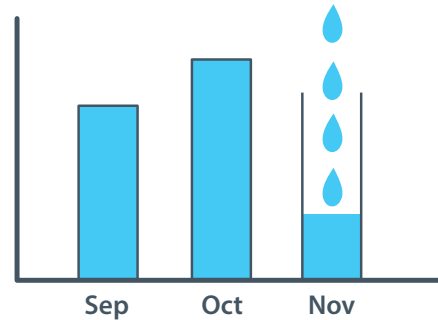

IoT Ready

The Sonata is a data collection end-point device coupled with an integrated radio, providing the foundation for a reliable and scalable AMI/AMR network, ready for any future application or challenge.

The Sonata supports LoRa® radio module also combined with a Wireless M-bus radio.

This data-rich sensor contributes important information to support decision making at the grid management level, as well as for on-site analysis.

Environmental Friendly

- Lead free, RoHS
- 12-year battery life span means no battery changes throughout the product lifespan
- Low head loss reduces energy demand



Technical Data

Standards

- MID (OIML R49:2013, EN 14154, ISO 4064:2014)
- NSF61+NSF372
- ACS
- IP68 (submersible)
- WRAS
- KTW

Technical Specifications

Head Loss	from 0.16 bar at Q3
Maximum Working Pressure	16 bar
Maximum Water Temperature	50°C
Body	PPS, highly reinforced composite material

Dimensions

Model	Sonata20	Sonata25
Size	DN20	DN25
L - Length (mm)	190	260
H – Overall height (mm)	117	121
h – Height above axis (mm)	80	82
W – Width (mm)	80	80
Threads	BSP	
Weight (kg)	0.900	

Flow Rate Performance Data:

Model	Q4 (m ³ /h)	Q3 (m ³ /h)	Q2 (l/h)	Q1 (l/h)	R	Starting flow (l/h)	Δp (bar)
Sonata20	3.1	2.5	8.0	5	500	2	0.16
	5.0	4.0	12.8	8	500	2	0.16
	5.0	4.0	12.8	8	500	3	0.16
Sonata25	7.9	6.3	20.2	12.6	500	3	0.16
	12.5	10.0	32.0	20	500	3	0.4

Installation Requirements

- Installation must be carried out according to the installation instructions available on the website.
- The meter can be installed in any position (horizontal, vertical or inclined).
- Prior to the installation of a new meter, the pipeline must be flushed.
- Install the water meter with the flow direction according to the arrow shown on the water meter. →

Head Loss Curve

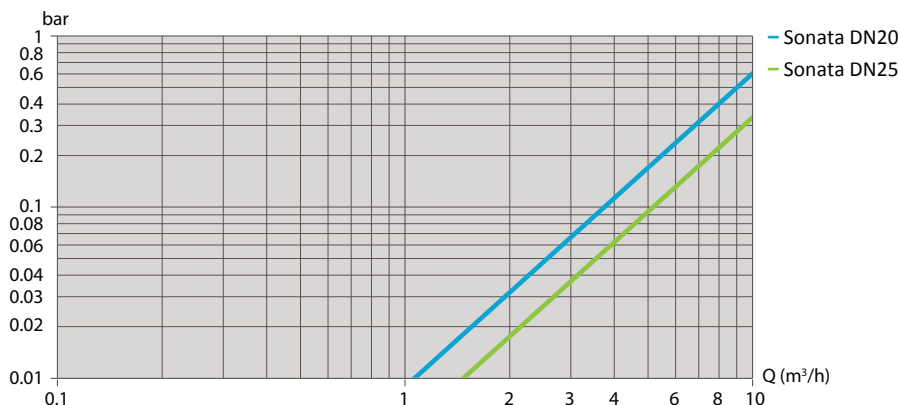

For the most updated version, please view our website: www.arad.co.il
Specifications are subject to change without notice.

Outputs:

- LORA communication
- Pulse output

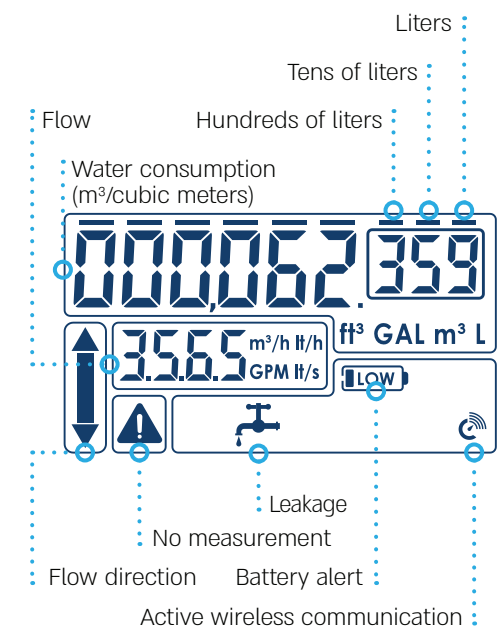
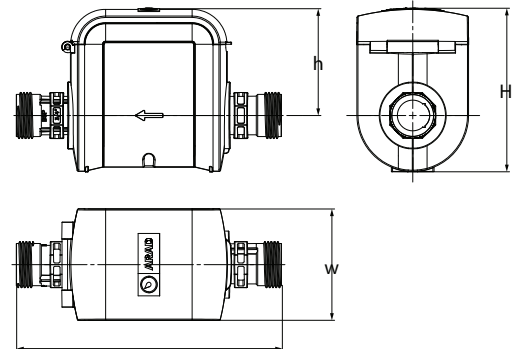

FARMER BOY
50 West Stoever Ave.
Myerstown, PA 17067
1-800-845-3374
www.farmerboyag.com